

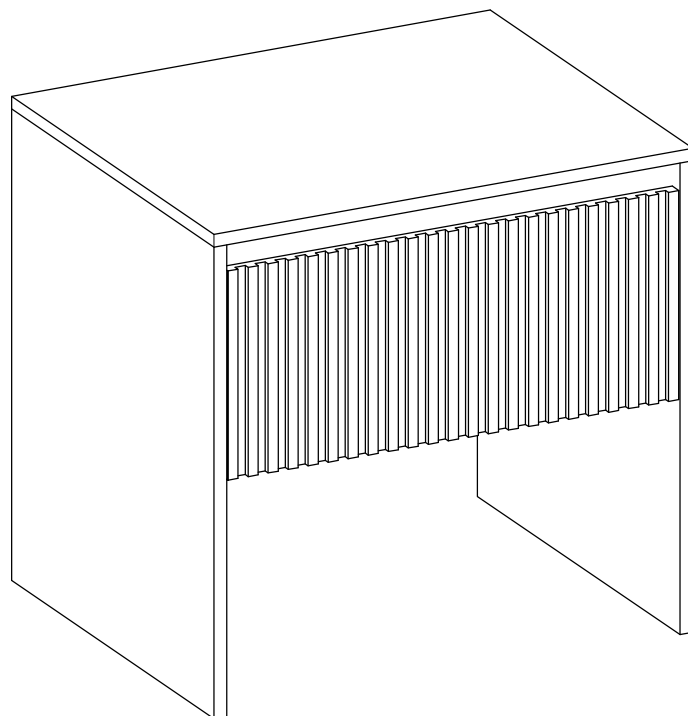













# VEMMI

SZAFKA NOCNA



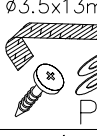

 A1 12	 C 12	 D1 12	 O 1	 C6 2	 D5 2	 D6 2	 I2 2	 P24 4	 R14 2		
 P4 1	 O11 1	 F1 4									

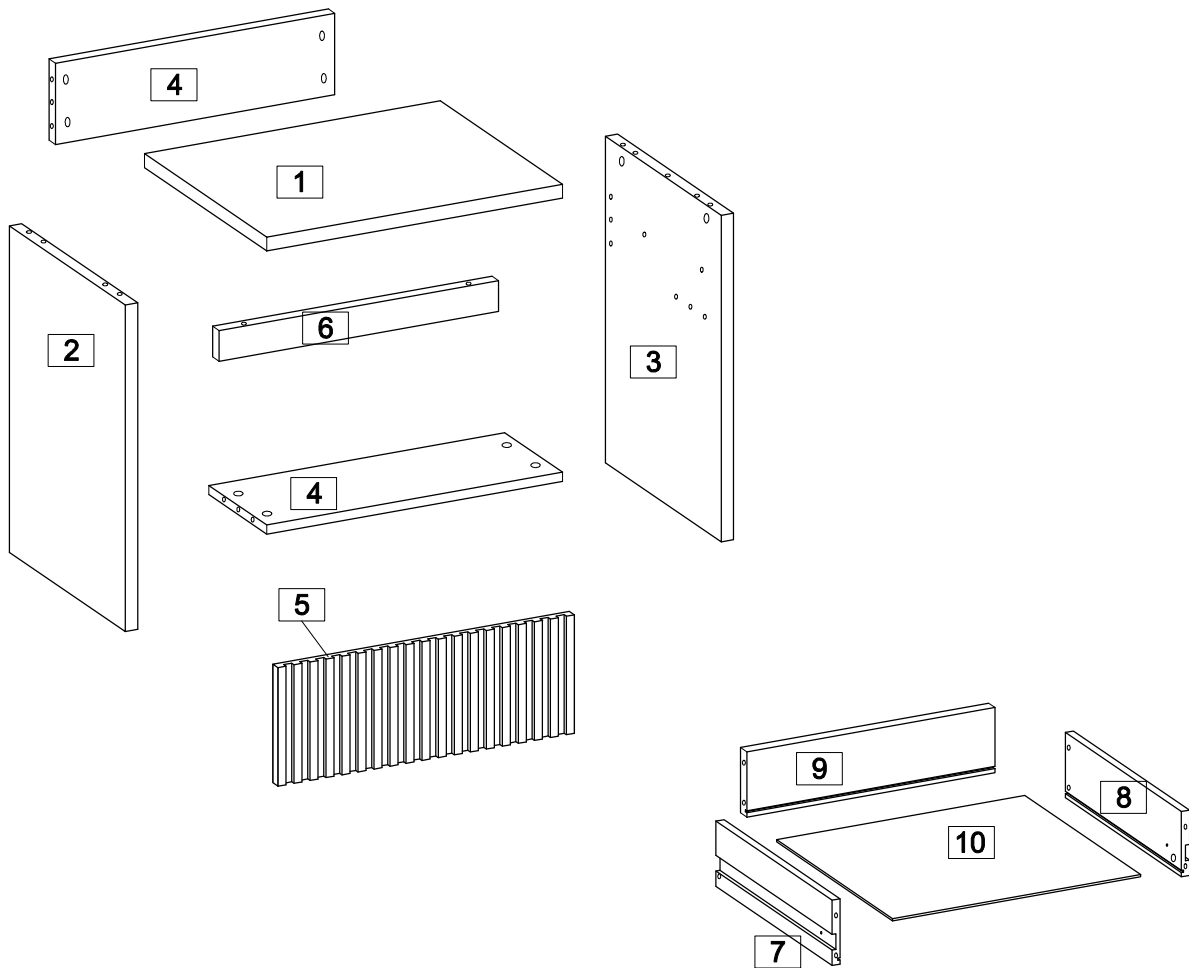
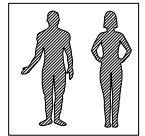

1	2	3	4	5	6	7	8	9	10		
450x370x22 mm	478x370x22 mm	478x370x22 mm	404x150x16 mm	160x400x16 mm	404x40x16 mm	300x100x12 mm	300x100x12 mm	372x100x12 mm	382x298x3 mm		
1x	1x	1x	2x	1x	1x	1x	1x	1x	1x		

# VEMMI

1

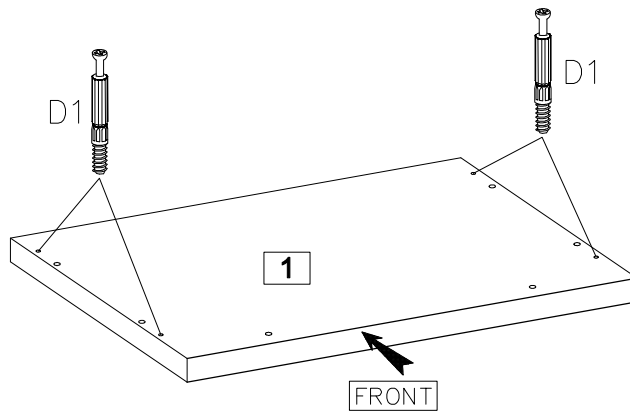
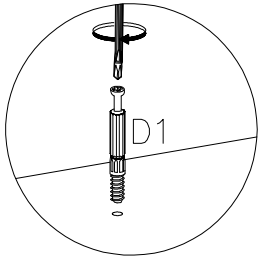
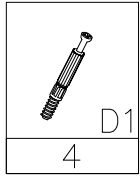

2

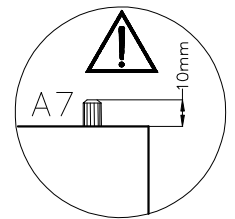
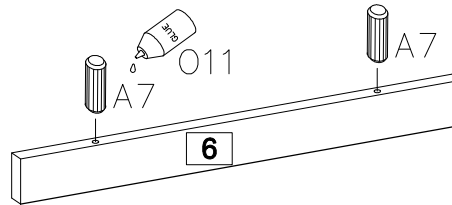
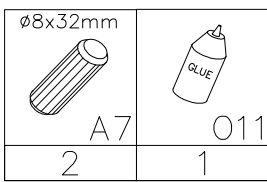

3

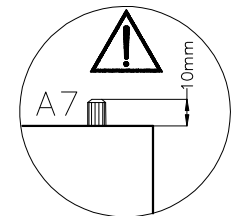
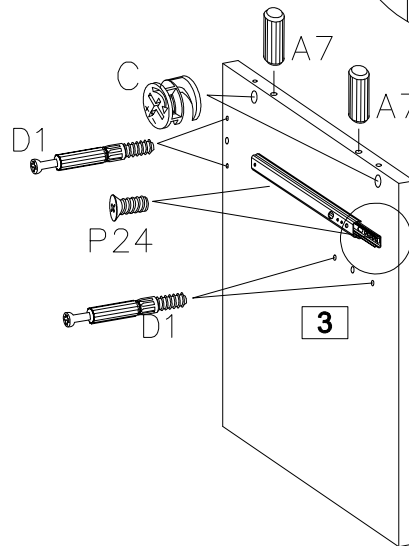
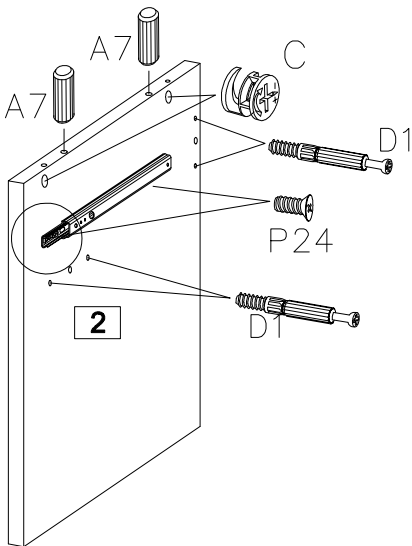
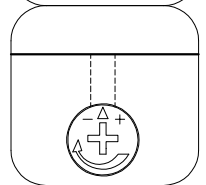
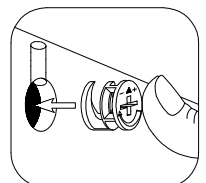
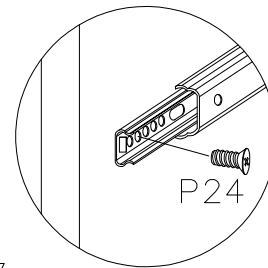
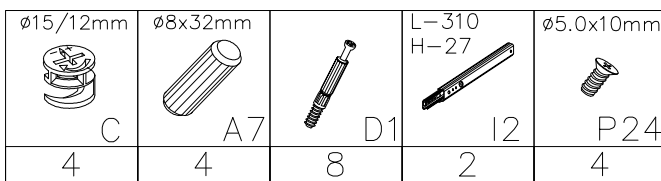

4

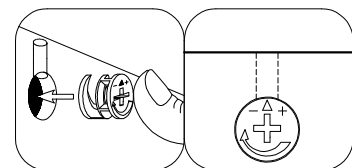
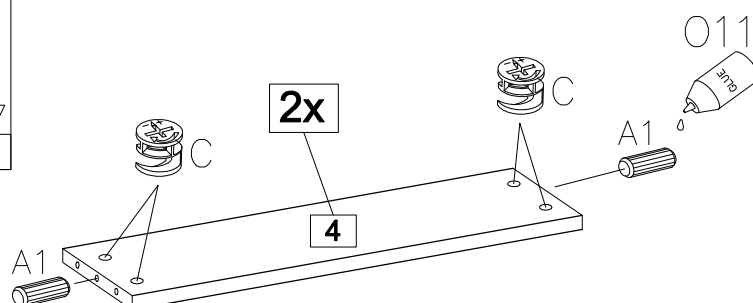
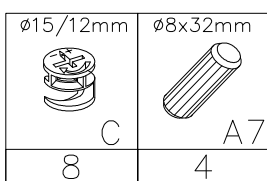

# VEMMI

5

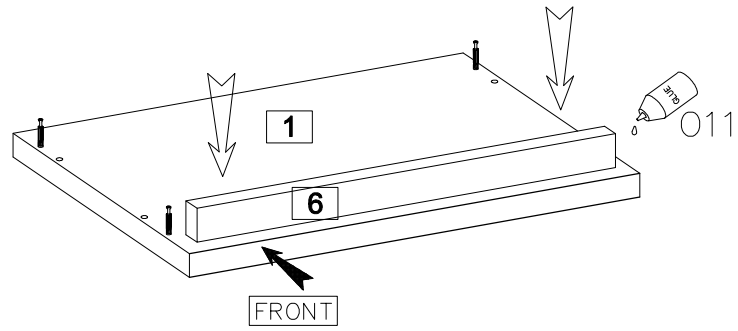
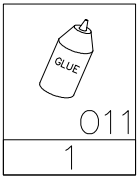

6

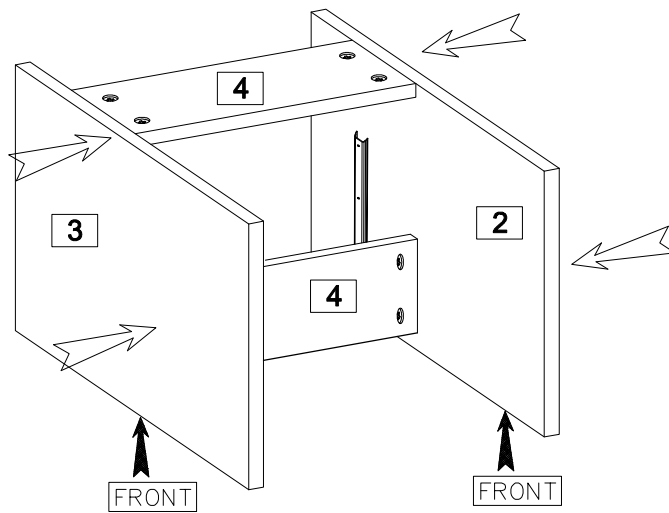



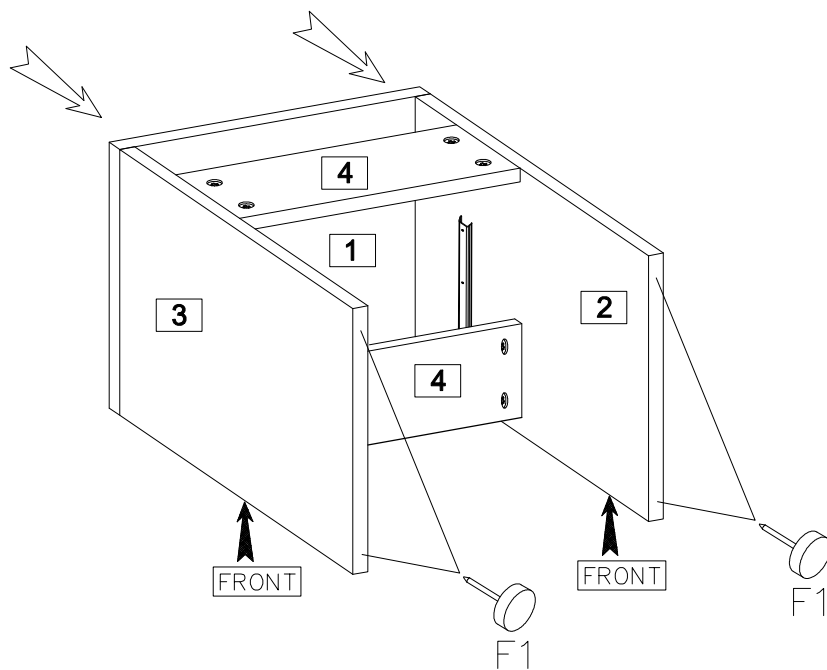
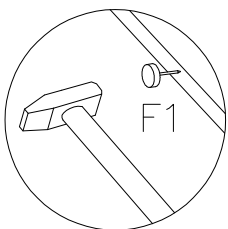
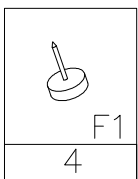

7

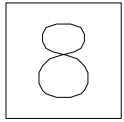

# VEMMI



$\varnothing 8 \times 32 \text{mm}$  A7	$\varnothing 12 / 10 \text{mm}$  C6	 O11	 D6
4	2	1	2

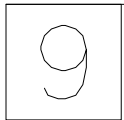
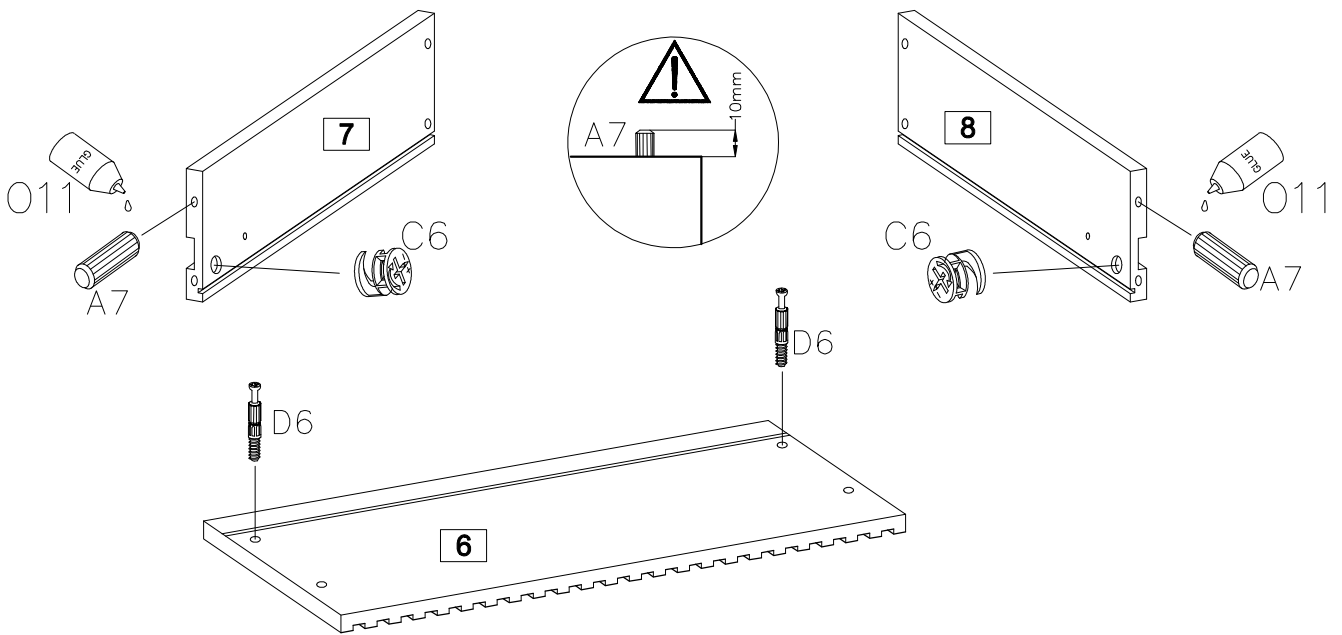
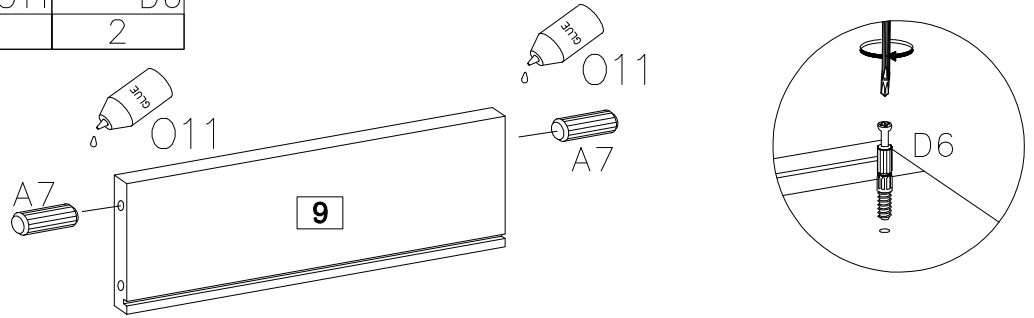

 D5
2

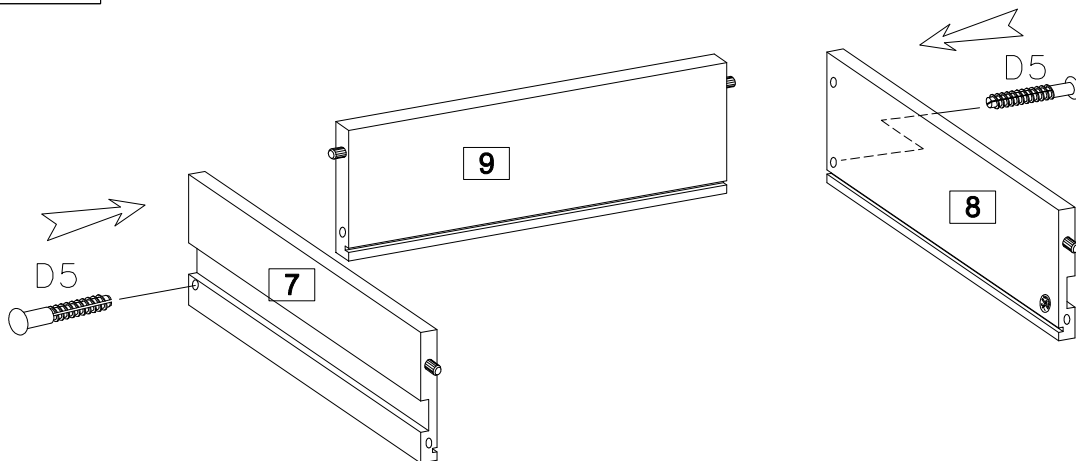
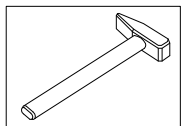

# VEMMI

10

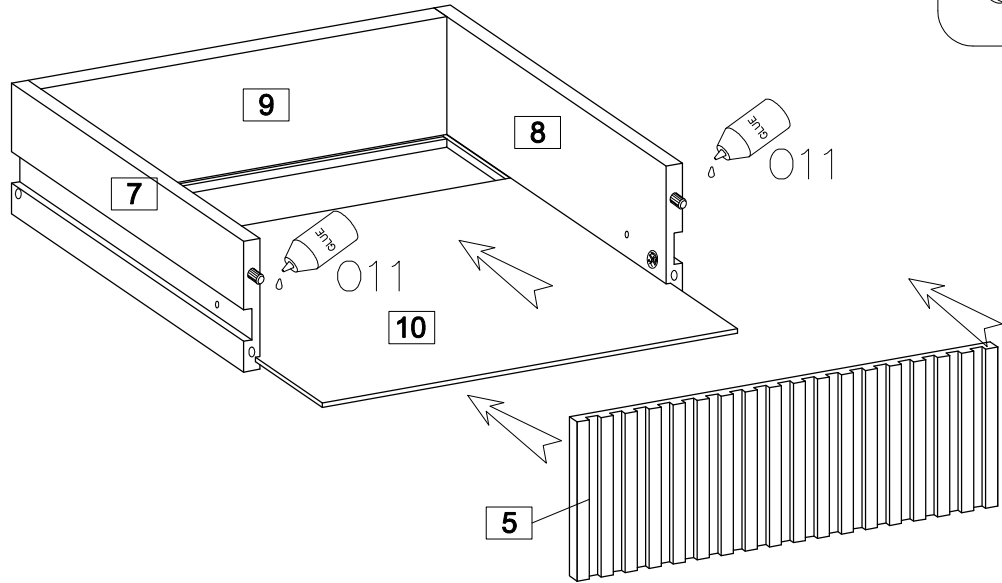
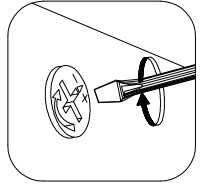
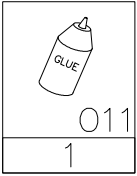

11

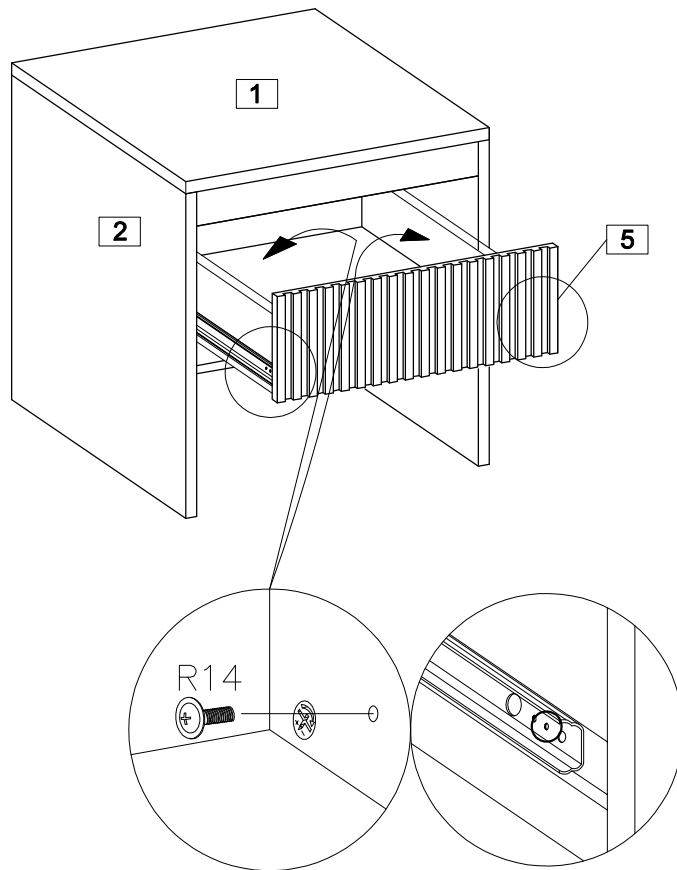

+S

VEMMI

12

A

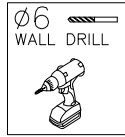

B

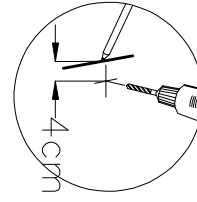

C

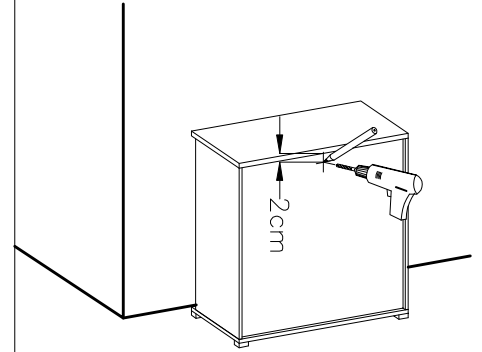
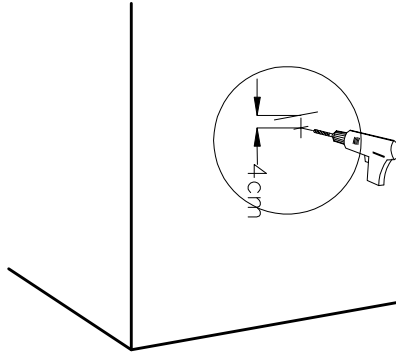
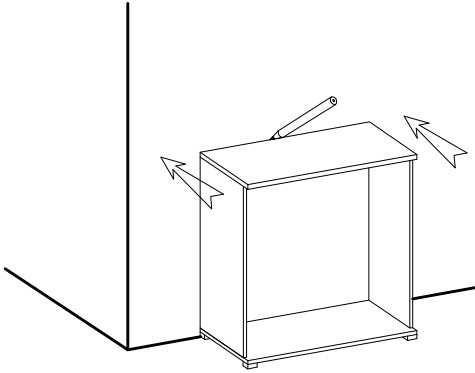
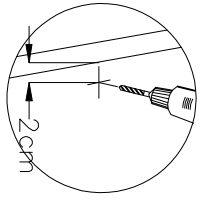

D

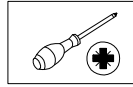

E

